

esrever

*a personal collection by Yeshey*

28/03/2022



Like any creator or Artists, I wait for ideas to show up, an inspiration to start my process. I look for visuals that might help me portray my ideas well. I look around for help. That's what I've done so far and that's what most of us do. I feel stuck, I read. I'm full of ideas I write. I've always found my main concept before I start creating. Now I keep thinking about this process, the process I've been proud of, wondering if this is the only way, if this is the only right way. I find in me the need to change something, to find something new. But what is new? how can we proceed an idea without looking at someone else's work? I wonder why I ask such questions to myself. But I've decided to unlearn certain things I do, certain habits, to break the routine, to break a circle. We have constantly been stuck in a cycle that we forget to notice. I want to incorporate that in my design process, not to do something entirely new but to change certain ways, unlearn habits and set off in a different path. Sustainability always plays a big role in my process but how can I improve it? Every little thing I do from here will count, Everything will be colourless until I find my main idea. But this is where I start.

*Dear Diary*

19.02.22

19.02.22

1. Introduction
2. Research
3. Techniques



05.02.22

# Pro- logue

*Starting a design journey with  
unlearning my old design habits*

05.02.22

yeshey/24/02/22

I took walks in the neighborhood  
I've never been before. The intention  
was not to find new ideas but  
to feel a new ambience.

The neighborhood is located  
of the 9th district of Paris but  
felt nothing like the busy  
It had its own charms.

As I enderemly  
not but gave  
an organic

Neighbourhood

Attention

out

at the edge

but honestly I used to know

Somehow quite calm,  
inspired by the place, maybe  
me space to think, a perspective,  
to my design process

19 and somewhere on the  
edge

Inspired from my previous collection Amtsu which advocates women's voice and the art of being a women, - this design journey majorly focuses on finding ways and techniques to reduce design wastes and creating a greener line of collection. But to amplify the creative part of this process, I have imagined a muse, a women that is solely how I want her to be. She drives my imagination and comes straight out from my fantasy journal. This collection is the portrayal of a personal journey where my dreams and fantasies meet my ethical values.



She is a violinist and a poet when she performs, she starts with one of her self written poems which narrates the story of her music.

she sets the mood with her calm poetry and the moment her audience locks in her world, she plays her sound.

The connection between her words and her music

she is my muse.



*Using the art of Reverse graffiti on upcycled textile*





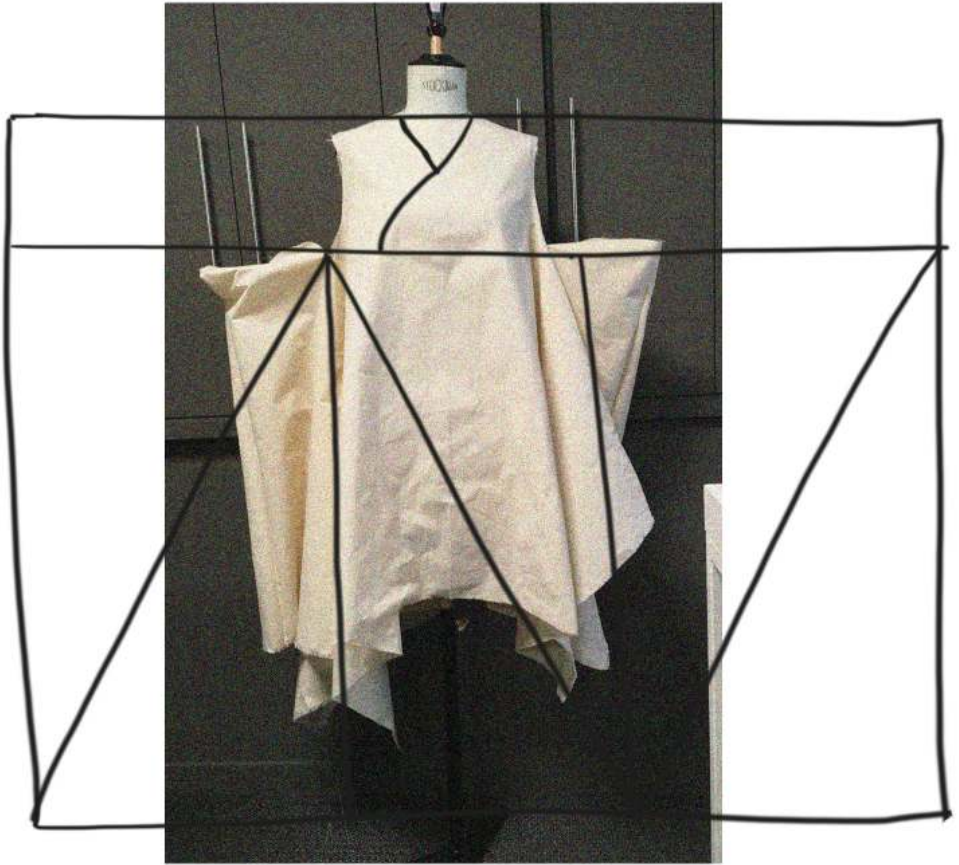

Patching by pieces  
↳  
Draping with no waste

Developing volume  
& shapes . . .

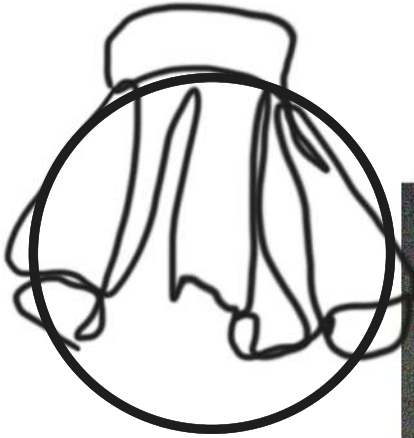

Draping process . . .

# Intrulude

o.I



*Unlearning old habits is not  
as easy as I thought, it has  
slowed me down into thinking  
alot and finding a new starting  
point*

1. Mood board
2. Colours
3. Inspiration

08.02.22



## POETRY

FOUNDED IN 1912 BY HARRIET MONROE

VOLUME C

NUMBER 5



ANNE SEXTON

### THE BLACK ART

A woman who writes feels too much,  
those trances and portents!  
As if cycles and children and islands  
weren't enough; as if mourners and gossips  
and vegetables were never enough.  
She thinks she can warn the stars.  
A writer is essentially a spy.  
Dear love, I am that girl.



271



OE

-

MOOD BOARD

*Colours*



No



Pantones



Colours

*How much further can we  
go on creating, my mental  
state is being challenged  
but the process needs to  
go on*

12.02.22

1. Refelection
2. Textiles
3. Expiriments

# Interlude

o.2



*One of the major unlearning process I've taken  
on as a designer is not giving myself option to  
source new material rather to take the chance  
and go with what I have Chez moi*

*12.02.22*

## Textile reflection

*I may not be able to use every single piece of textile I have but I believe its a great step and a challange to reuse, recycle, and re-construct. To make the best use of exist-ing matters.*



*Mixture of Organza  
made of cotton and some  
with polyster*

*Use: look 1,3,4,8*

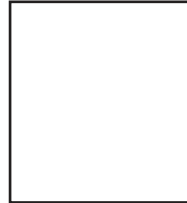

*100% cotton corduroy  
with Machine embriodery  
and secquence*

*Use: look 4, 5, 8*



*Polyster crep like  
texture*

*Use: look 5, 6,*



*light weight crepe  
100% silk*

*Use: look 5, 8*

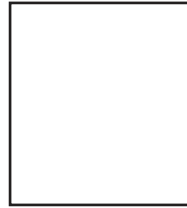

*polyster elesthane  
with subtle coloured  
flower prints*

*Use: look 5,6,8*

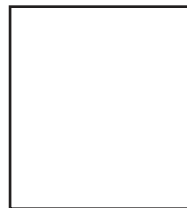

*70% cotton, 30% silk  
shiny & gradient  
texture*

*Use: look 5,6,8*



*Polyster with taftea  
like feel, with hori-  
zantal lines*

*Use: look 1, 3, 7, 8*

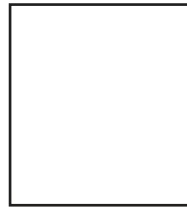

*100% silk  
light weight satin*

*Use: look 1, 7, 8*

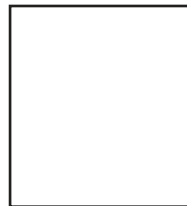

*Part cotton, part syn-  
thetic with elasthan*

*Use: look 1, 2, 4, 7, 8*

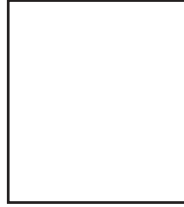

*100% silk  
satin like texture  
and very relective*

*Use: look 2, 5, 8*

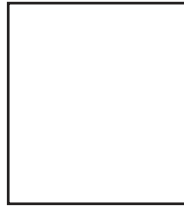

*Mixture of nylon  
tulle  
light weight & heave  
weight.Used mainly as  
lining for volume*

*Use: look 1, 4, 7*

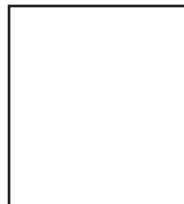

*Recycled old denims  
100% cottons and  
various shade of  
colours*

*Use: look 2, 3, 8*



*Experimentation of reverse graffiti on upcycled denim*



*Mixing, patching, ruffling*

*Free-style patchworking of  
organzas  
to make bigger pieces of  
fabrics*





*In the making of look 1*



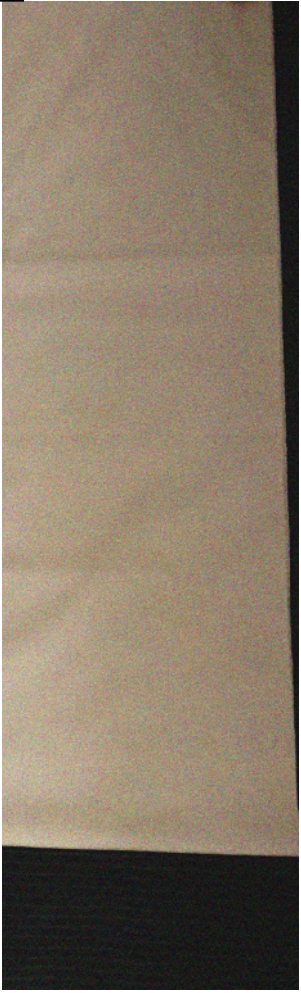

*ruffling, pipings*



# Epi- logue

*Regardless of the challenges, as  
creator I shall never stop finding  
better solutions so art and etchings  
could grow together.*

24.02.22

1. collection
2. Technicals
3. Endings



24.02.22

Look 1



Look 11



Look 111



Look 1111



Look 11111



Look 111111



Look 11111111



Look 11111111



Look 1 Volumed dress

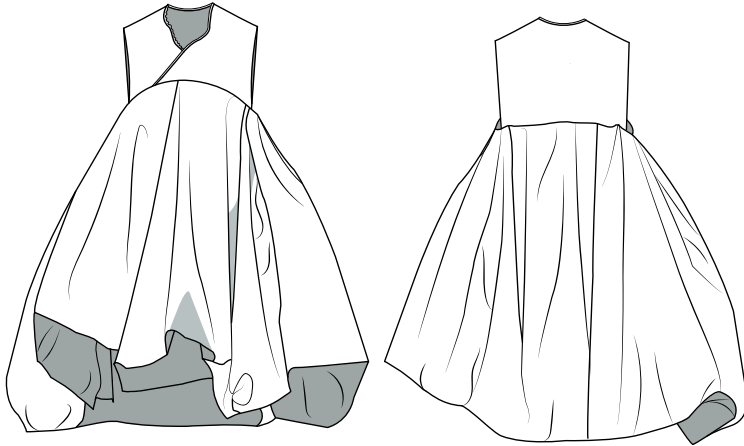

Trimmings: Ruffel pipings, snap buttons, bias tape

Low waste technique

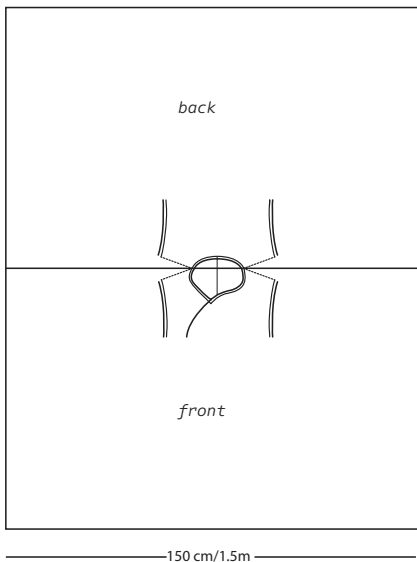
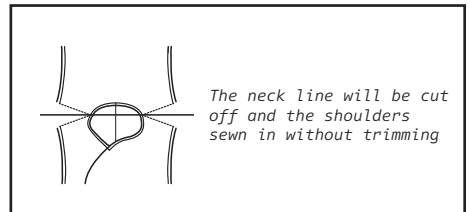

300 cm / 3m



After cutting of the neck part put it on the dummy to let it flow and start draping

Look 1 Volumed dress pattern

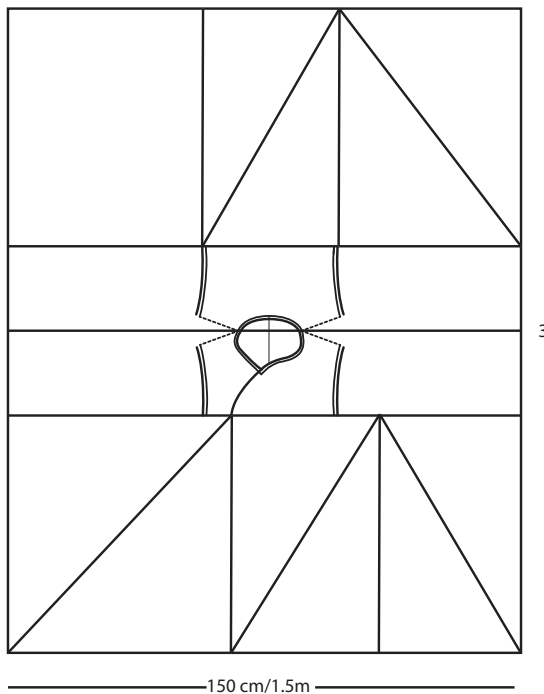

*Different bits of fabrics  
can be layed on the big  
pattern to be patched and  
re-draped*

*Avoid trimming while draping*

low waste long sleeved top  
for look 1, 4

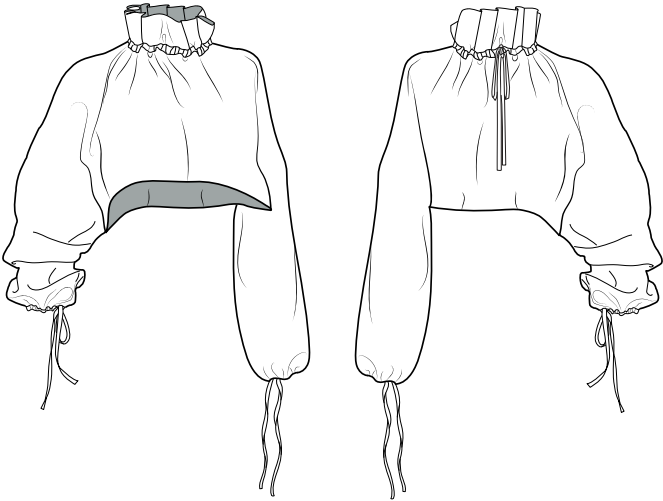

*Collar stand*



*Draw string*

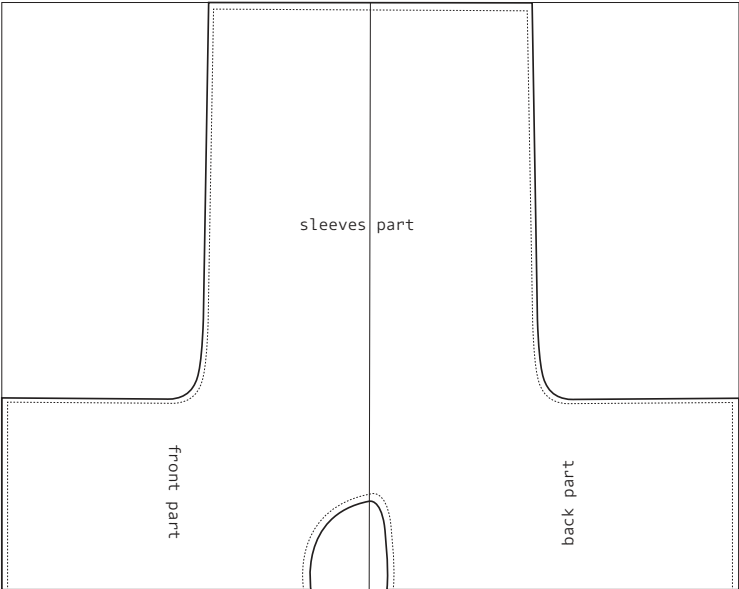

low waste short sleeved  
top for look 1, 4

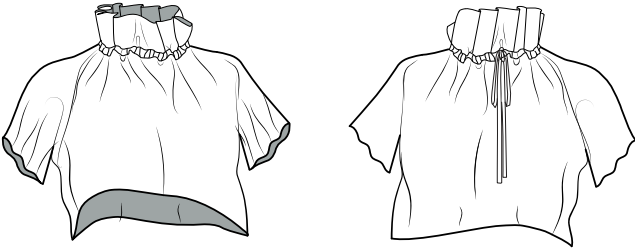

*The remaining bits of fabric is used to make bias tape for the finishing of the tops*

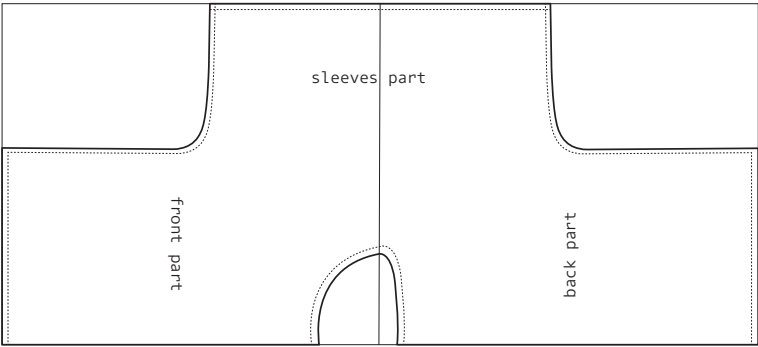
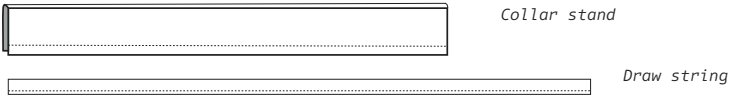

low waste dress with long sleeves for look 5

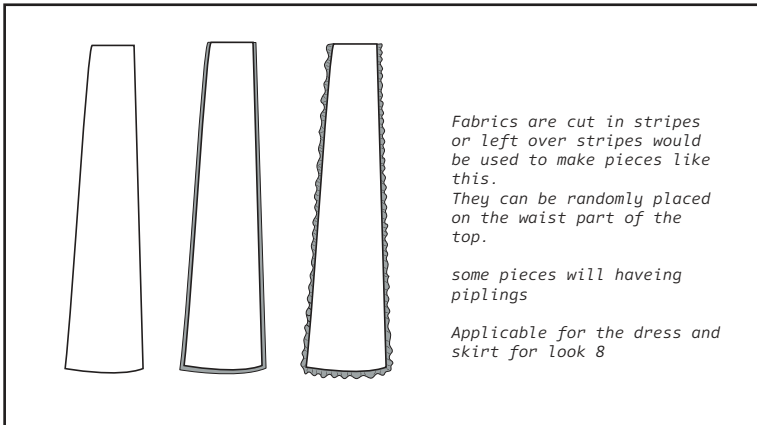

*Trimmings: Ruffel pipings, invisible zipper, bias tape*

low waste skirt for  
look 8

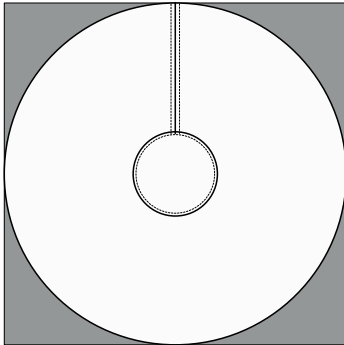
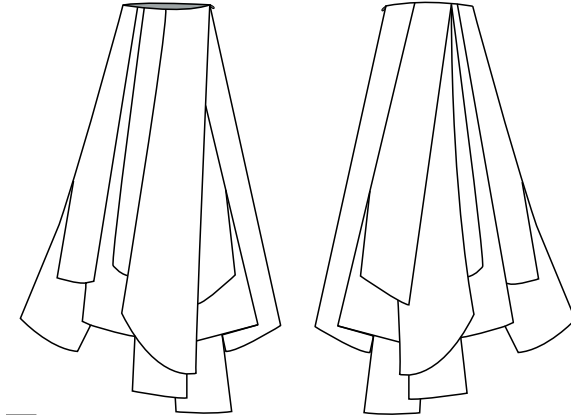

*Circle pattern lining for look 5 and look 8  
Finished with bias tape and top stitch*

*Trimings: Ruffel pipings, invisible zipper, bias  
tape*

low waste dress for look 7

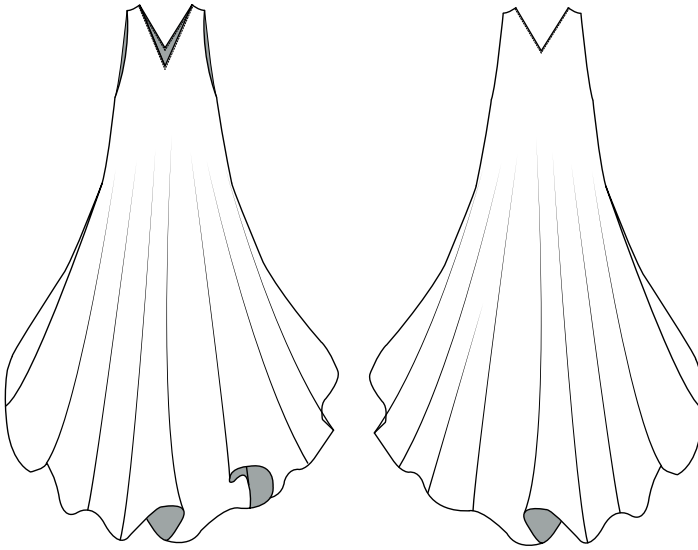

low waste uncycling dress/  
top for look 2

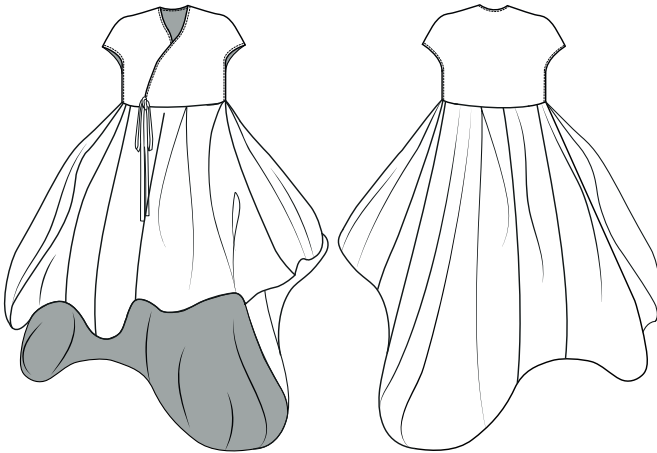

*Trimmings: patchwork, snap buttons, drawstring,  
bias tape*

low waste dress for  
look 4

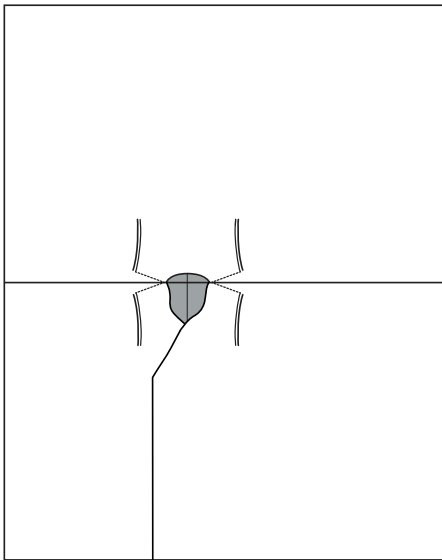
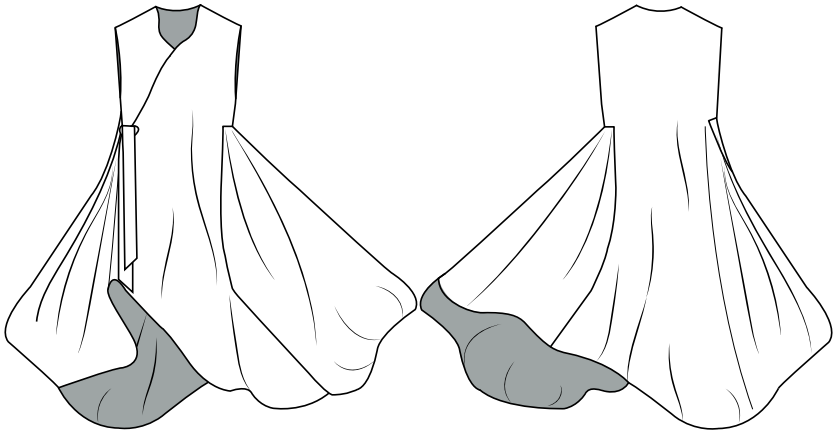

300 cm/ 3m

*similar technique to look  
one with different draping*

150 cm/1.5m

*Trimings: snap buttons, drawstring, bias tape*

low waste top for look 6

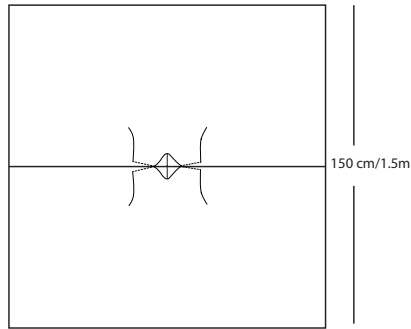
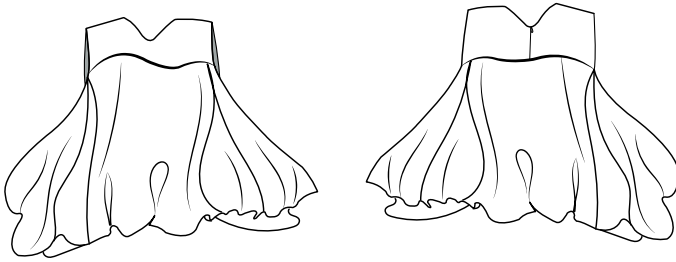

similar technique to look one for small scale draping

low waste top for look 2

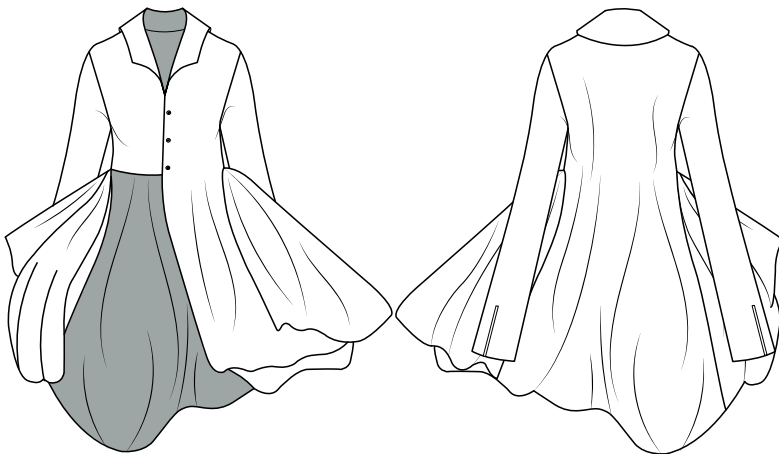

Trimmings: pipings, lining, buttons



Sleeveless coat for  
look 5

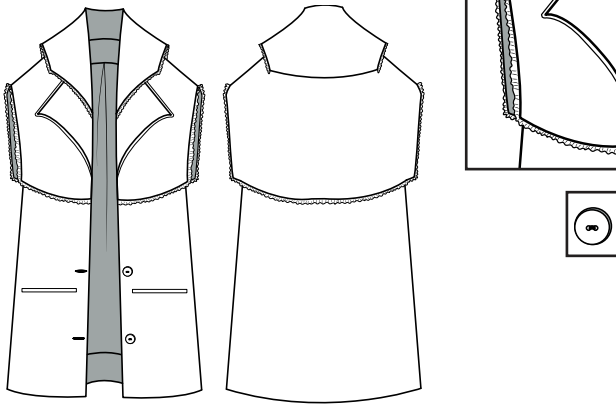

*Trimmings: pipings, lining, buttons, welt pocket*

low waste dress for  
look 4

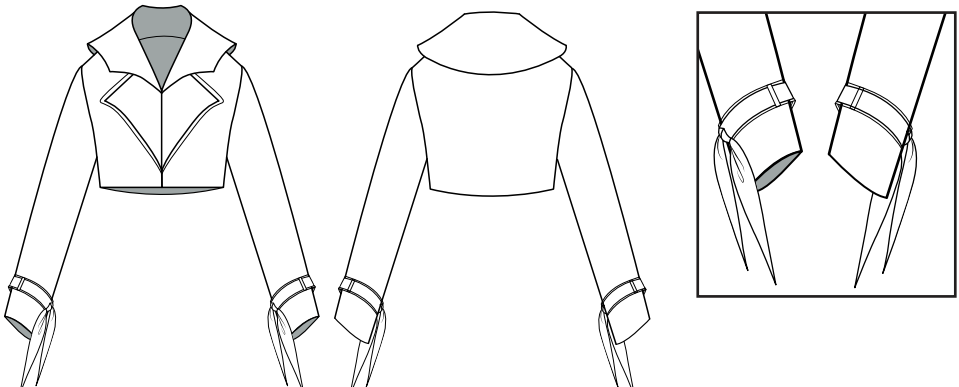

*Trimmings: pipings, lining, snap buttons, piped  
sleeve belt*

Up-cycled trouser for look 3

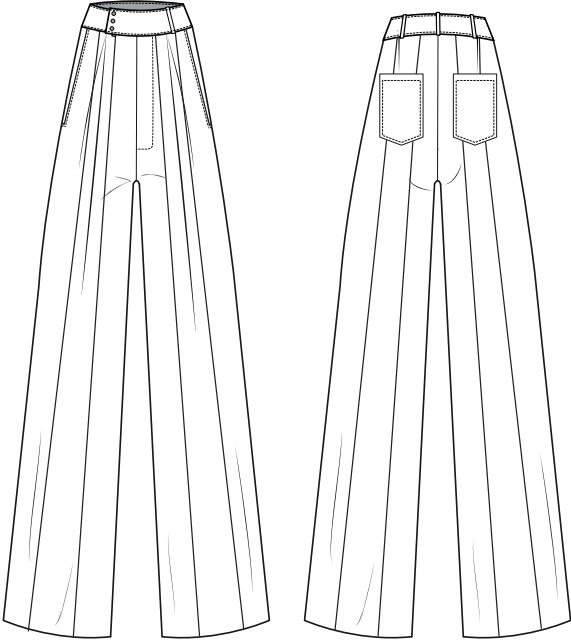
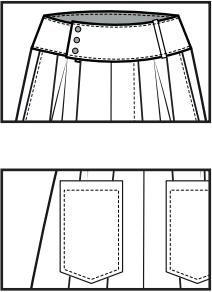

*Trimmings: ruffel piping, buttons, top stitch, patch work*  
*Both of the trousers share same pattern*

Up-cycled trouser for look 2

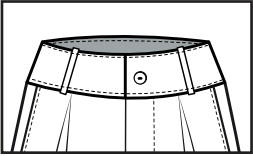
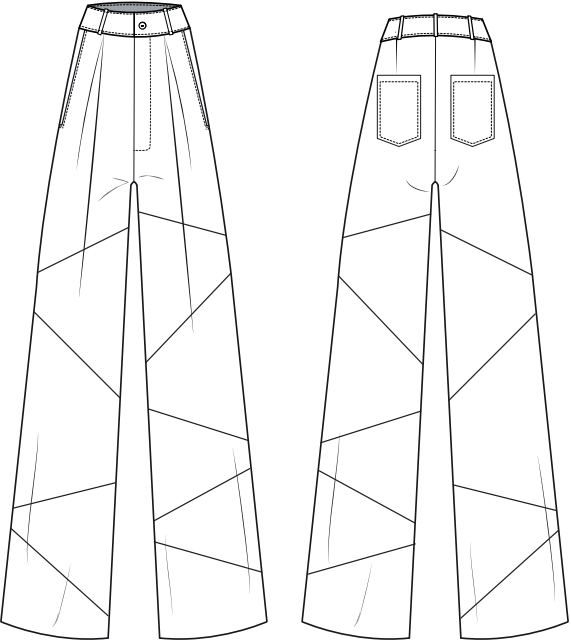

Knee length shorts for  
look 6

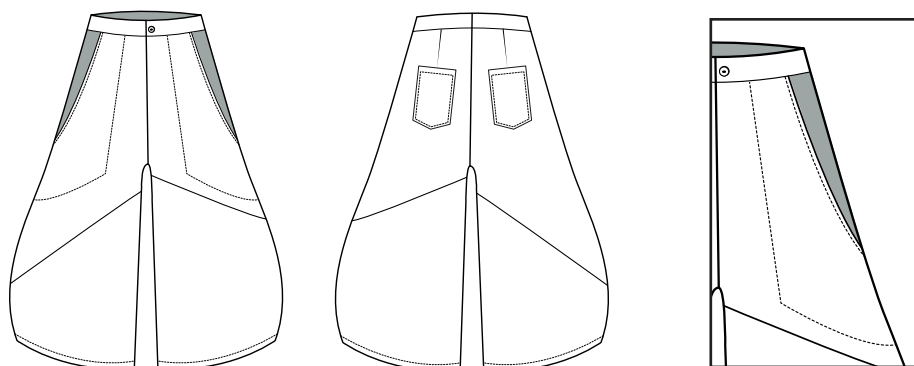

*Trimmings: Pippings, button, pockets, patch work*

To be continued

